



## CF-12V12



### CAREFREE RECHARGEABLE - LEAD ACID

<b>Product Name</b>	Sealed Lead Acid(SLA)
<b>Technology</b>	AGM

### APPLICATIONS

Airports; Emergency; Industrial; Medical;  
Military; Navigation; Railroad Signals;  
Residential; Security; Specialized Products;  
UPS/Lighting

### PERFORMANCE SPECIFICATIONS

<b>Voltage (Volts)</b>	12
<b>Capacity (Amp-Hours)</b>	12

### DIMENSIONS AND WEIGHT

<b>Width/Diameter (Inches)</b>	3.86
<b>Length/Depth (Inches)</b>	5.95
<b>Height/Thickness (Inches)</b>	3.74
<b>Weight (Pounds)</b>	9.25

### PRODUCT NOTES

Terminal is tin plated brass, ABS case material

### SPECIFICATIONS CF-6V12

Nominal Voltage ..... 6V  
 Nominal Capacity at 77°F (25°C) Voltage readings are per cell  
 20 Hour Rate (0.60 amps to 1.75 volts).. 12.00 ampere hours  
 10 Hour Rate (1.12 amps to 1.75 volts).. 11.20 ampere hours  
 5 Hour Rate (1.92 amps to 1.75 volts)..... 9.60 ampere hours  
 1 Hour Rate (7.75 amps to 1.60 volts)..... 7.75 ampere hours  
 1/2 Hour Rate (12.6 amps to 1.60 volts).. 6.30 ampere hours  
 Max. Physical Size  
 Length ..... 5.95 inches (151mm)  
 Width..... 1.97 inches (50mm)  
 Height (excluding terminals) ..... 3.70 inches (94mm)  
 Height (including terminals)..... 3.94 inches (100mm)  
 Weight ..... 4.63 lbs (2.10kg)  
 Energy Density  
 (20 Hour Rate) ..... 1.66 watt hrs/cu in  
 (20 Hour Rate) ..... 15.55 watt hrs/lbs  
 Operating Temperature Range  
 Discharge ..... -60°F to +140°F (-51°C to +60°C)  
 Charge ..... 0°F to +120°F (-18°C to +49°C)  
 Recharging Methods:  
 Float Charging: Constant Potential Source of 6.8 to 6.9 volts continuously.  
 Routine Charging: Constant Potential Source of 7.25 to 7.45 volts with a charging current of 4.0 ampere maximum.  
 Terminal: Standard is tin plated brass, positive terminal is 0.030 stock by 0.187 wide, negative terminal is 0.030 stock by 0.187 wide, mates with Amp Faston series or equal.  
 Case Material: ABS



### PRODUCT SCHEMATICS

### SPECIFICATIONS CF-12V12

Nominal Voltage ..... 12V  
 Nominal Capacity at 77°F (25°C) Voltage readings are per cell  
 20 Hour Rate (0.60 amps to 1.75 volts) ..... 12 ampere hours  
 10 Hour Rate (1.12 amps to 1.75 volts).... 11.2 ampere hours  
 5 Hour Rate (1.92 amps to 1.75 volts)..... 9.6 ampere hours  
 1 Hour Rate (7.75 amps to 1.60 volts)..... 7.75 ampere hours  
 1/2 Hour Rate (12.6 amps to 1.60 volts).... 6.3 ampere hours  
 Max. Physical Size  
 Length ..... 5.95 inches (151mm)  
 Width..... 3.86 inches (98mm)  
 Height (excluding terminals) ..... 3.74 inches (95mm)  
 Height (including terminals)..... 3.97 inches (101mm)  
 Weight ..... 9.25 lbs (4.2kg)  
 Energy Density  
 (20 Hour Rate) ..... 1.70 watt hrs/cu in  
 (20 Hour Rate) ..... 16.27 watt hrs/lbs  
 Operating Temperature Range  
 Discharge ..... -60°F to +140°F (-51°C to +60°C)  
 Charge ..... 0°F to +120°F (-18°C to +49°C)  
 Recharging Methods:  
 Float Charging: Constant Potential Source of 13.6 to 13.8 volts continuously.  
 Routine Charging: Constant Potential Source of 14.5 to 14.9 volts with a charging current of 4.0 ampere maximum.  
 Terminal: Standard is tin plated brass, positive terminal is 0.030 stock by 0.187 wide, negative terminal is 0.030 stock by 0.187 wide, mates with Amp Faston series or equal.  
 Case Material: ABS

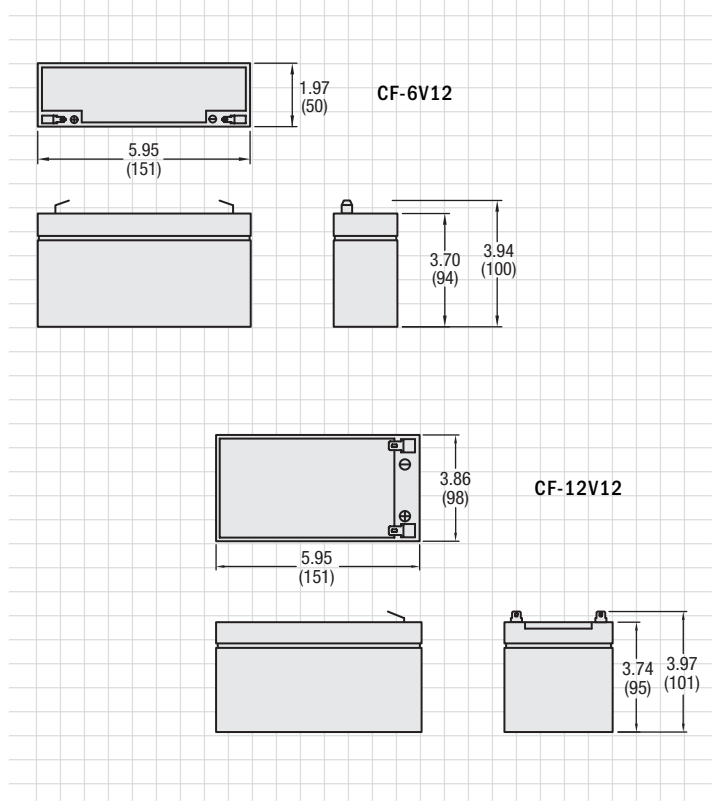

Above data are average values which can be obtained within 3 charge/discharge cycles. These are not minimum values.